



**DISTRIBUTORI
OLEODINAMICI**

M-SED6

DIRECTIONAL SEAT VALVES

THE DIRECTIONAL VALVE TYPE M-SED6 IS A DIRECT OPERATED DIRECTIONAL SEAT VALVE WITH SOLENOID ACTUATION. IT CONTROLS START, STOP AND DIRECTION OF THE FLOW AND BASICALLY COMPRISES A HOUSING, SOLENOID, VALVE SEATS AND CLOSING ELEMENT. THE MANUAL OVERRIDE ALLOWS FOR THE OPERATION OF THE VALVE WITHOUT SOLENOID ENERGIZATION.

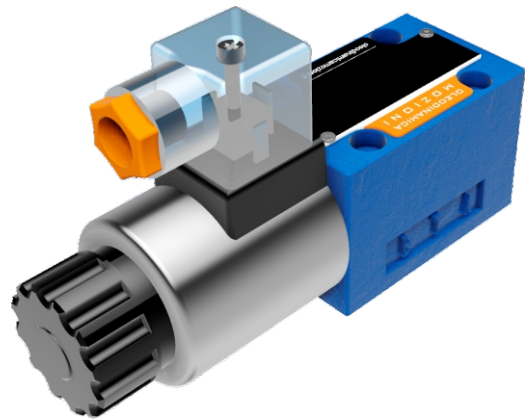

TECHNICAL DATA

SIZE		6
MAX. FLOW RATE (L/MIN)		25
OPERATING PRESSURE (MPA)		35
FLUID TEMPERATURE (°C)		-30 – 80
FILTRATION ACCURACY (µM)		10
WEIGHT (KG)	3/2 VALVE	1.5
	4/2 VALVE	2.3
VALVE BODY (MATERIAL)		CASTING PHOSPHATING SURFACE



CHARACTERISTIC CURVES

ΔP -Q CHARACTERISTIC CURVES
3/2 DIRECTIONAL SEAT VALVE

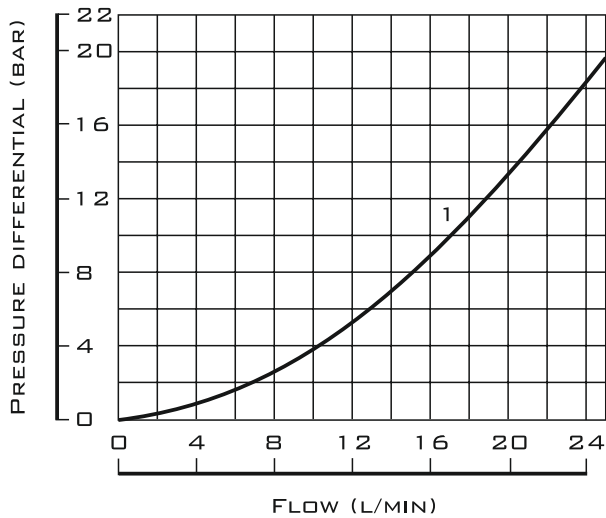

1 - M-3SED 6 UK/CK..., P → A;

ΔP -Q CHARACTERISTIC CURVES
4/2 DIRECTIONAL SEAT VALVE

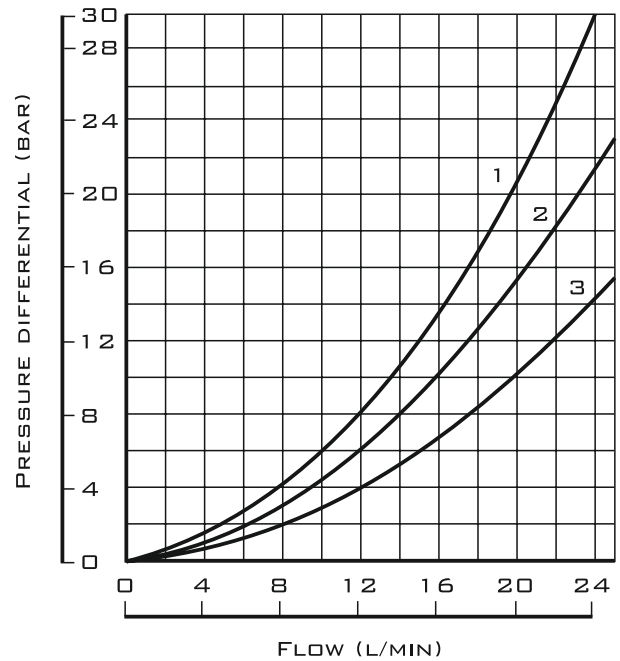

1 - M-4SED 6 D/Y..., A → T;
2 - M-4SED 6 D/Y..., P → A;
3 - M-4SED 6 D/Y..., B → T, P → B;

ΔP -Q CHARACTERISTIC CURVES
CHECK VALVE INSERT

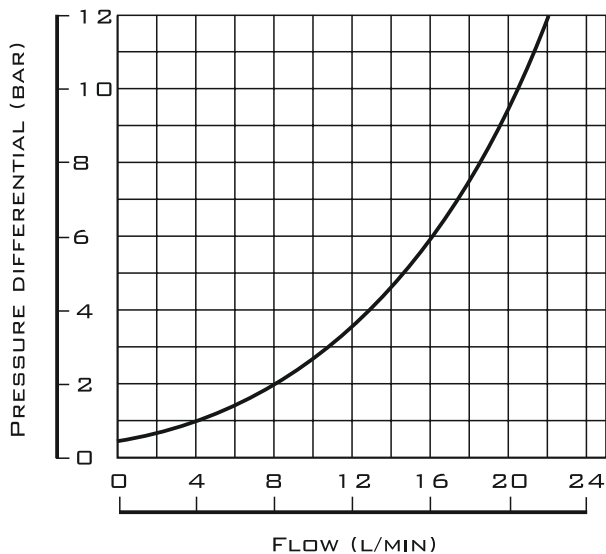

ΔP -Q CHARACTERISTIC CURVES
THROTTLE INSERT

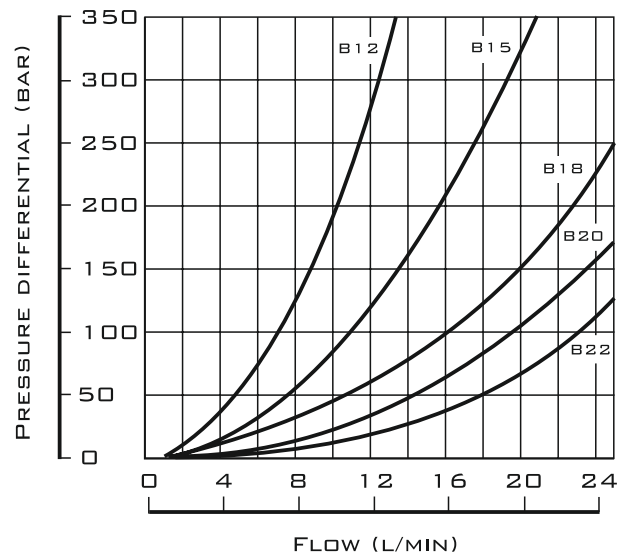

SEE ALSO:
M-SEW6

SPOOL SYMBOLS

3/2 DIRECTIONAL SEAT VALVE

UK

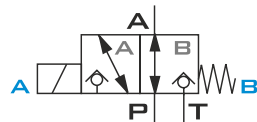

CK

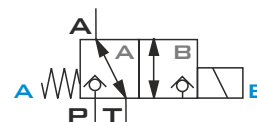

THE INITIAL POSITION OF THE VALVE (NORMALLY OPEN "UK" OR NORMALLY CLOSED "CK") IS DETERMINED BY THE ARRANGEMENT OF THE SPRING (5). THE CHAMBER (3) BEHIND THE CLOSING ELEMENT (4) IS CONNECTED TO PORT P AND SEALED AGAINST PORT T. THUS, THE VALVE IS PRESSURE-COMPENSATED IN RELATION TO THE ACTUATING FORCES (SOLENOID AND SPRING).

DUE TO THE SPECIAL CLOSING ELEMENT (4), PORTS P, A AND T CAN BE LOADED WITH THE MAXIMUM OPERATING PRESSURE (350 BAR) AND THE FLOW CAN BE DIRECTED INTO BOTH DIRECTIONS (SEE SYMBOLS). IN THE INITIAL POSITION, THE CLOSING ELEMENT (4) IS PRESSED ONTO THE SEAT (1 1) BY THE SPRING (5), IN OPERATED POSITION ONTO THE SEAT (7) BY THE SOLENOID (2). THE FLOW IS BLOCKED.

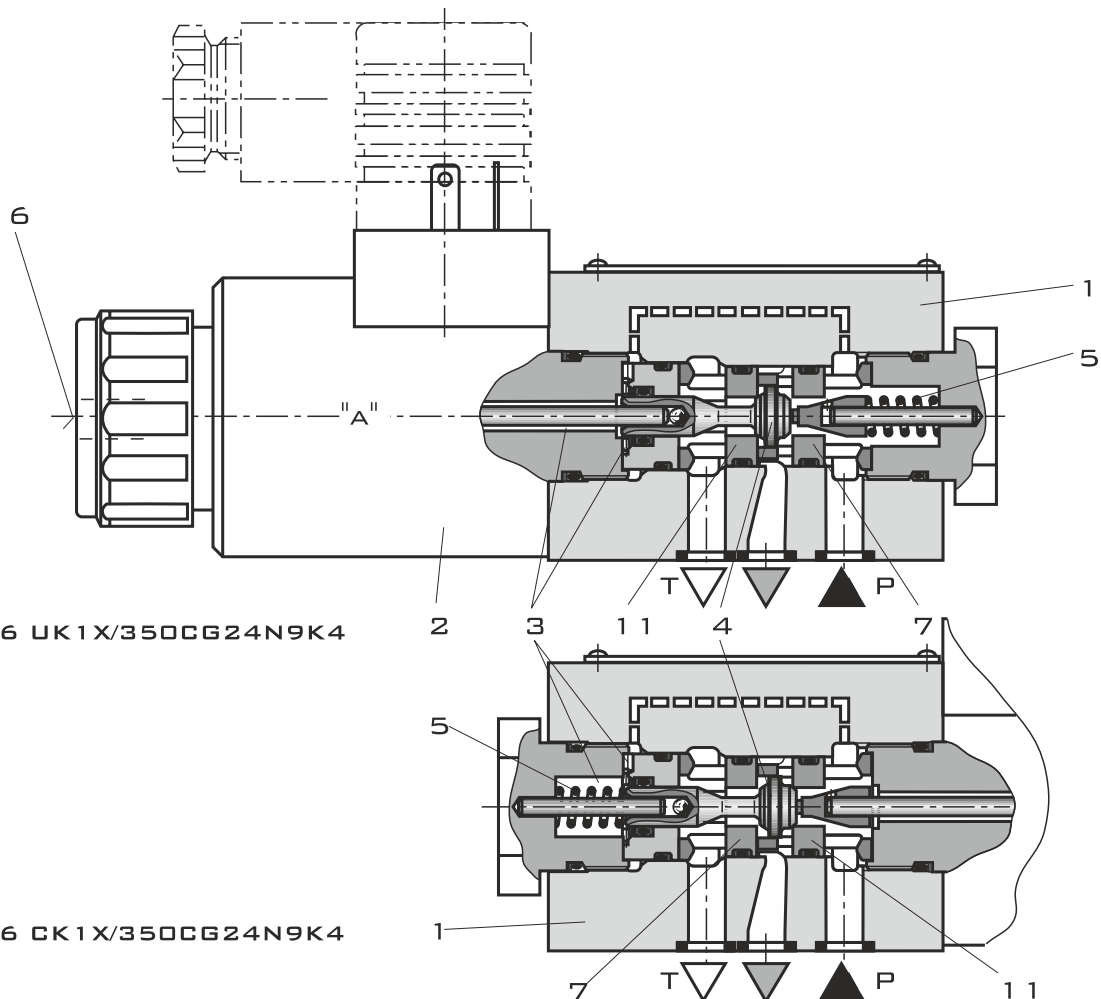

M-3SED 6 UK1X/350CG24N9K4

M-3SED 6 CK1X/350CG24N9K4

SPOOL SYMBOLS

4/2 DIRECTIONAL SEAT VALVE



WITH A SANDWICH PLATE, THE **PLUS-1** PLATE UNDER THE 3/2 DIRECTIONAL SEAT VALVE, THE FUNCTION OF A 4/2 DIRECTIONAL SEAT VALVE IS ACHIEVED.

FUNCTION OF THE PLUS-1 PLATE

INITIAL POSITION: THE MAIN VALVE IS NOT OPERATED. THE SPRING (5) HOLDS THE CLOSING ELEMENT (4) ON THE SEAT (11). PORT P IS BLOCKED AND A IS CONNECTED TO T. ONE PILOT LINE IS CONNECTED FROM A TO THE LARGE AREA OF THE PILOT SPOOL (8), WHICH IS THUS UNLOADED TO THE TANK. THE PRESSURE APPLIED VIA P NOW PUSHES THE BALL (9) ONTO THE SEAT (10). NOW, P IS CONNECTED TO B, AND A TO T.

TRANSITION POSITION: WHEN THE MAIN VALVE IS OPERATED, THE CLOSING ELEMENT (4) IS SHIFTED AGAINST THE SPRING (5) AND PRESSED ONTO THE SEAT (7). DURING THIS, PORT T IS CLOSED; P, A AND B ARE BRIEFLY CONNECTED TO EACH OTHER.

SPOOL POSITION: P IS CONNECTED TO A. BECAUSE THE PUMP PRESSURE ACTS VIA A ON THE LARGE AREA OF THE PILOT SPOOL (8), THE BALL (9) IS PRESSED ONTO THE SEAT (12). THUS, B IS CONNECTED TO T, AND P TO A. THE BALL (9) IN THE **PLUS-1** PLATE HAS A "POSITIVE SPOOL OVERLAP".

ATTENTION!

TO PREVENT PRESSURE INTENSIFICATION IN CONJUNCTION WITH SINGLE-ROD CYLINDERS, THE ANNULUS AREA OF THE CYLINDER MUST BE CONNECTED TO A.

THE USE OF THE PLUS-1 PLATE AND THE SEAT ARRANGEMENT OFFER THE FOLLOWING OPTIONS OF SYMBOL "D" OR "Y".

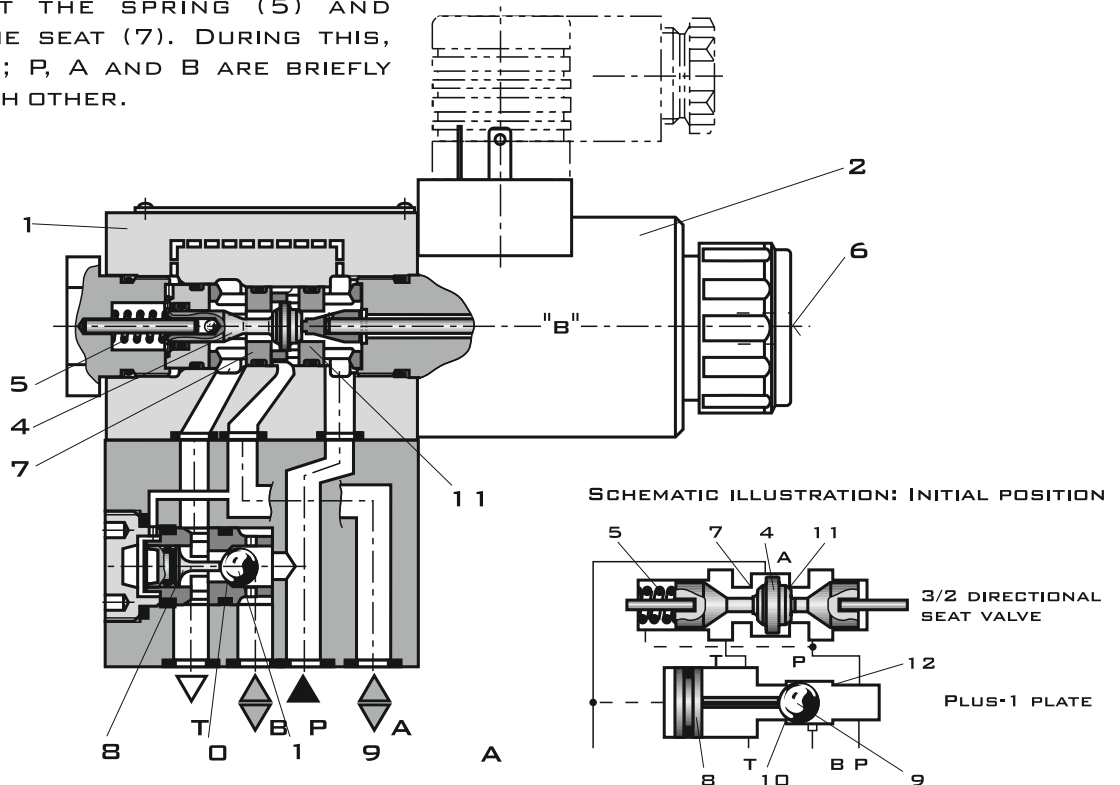

M-4SED 6 Y1X/350CG24N9K4

SUBPLATE INSTALLATION DIMENSIONS

3/2 DIRECTIONAL SEAT VALVE

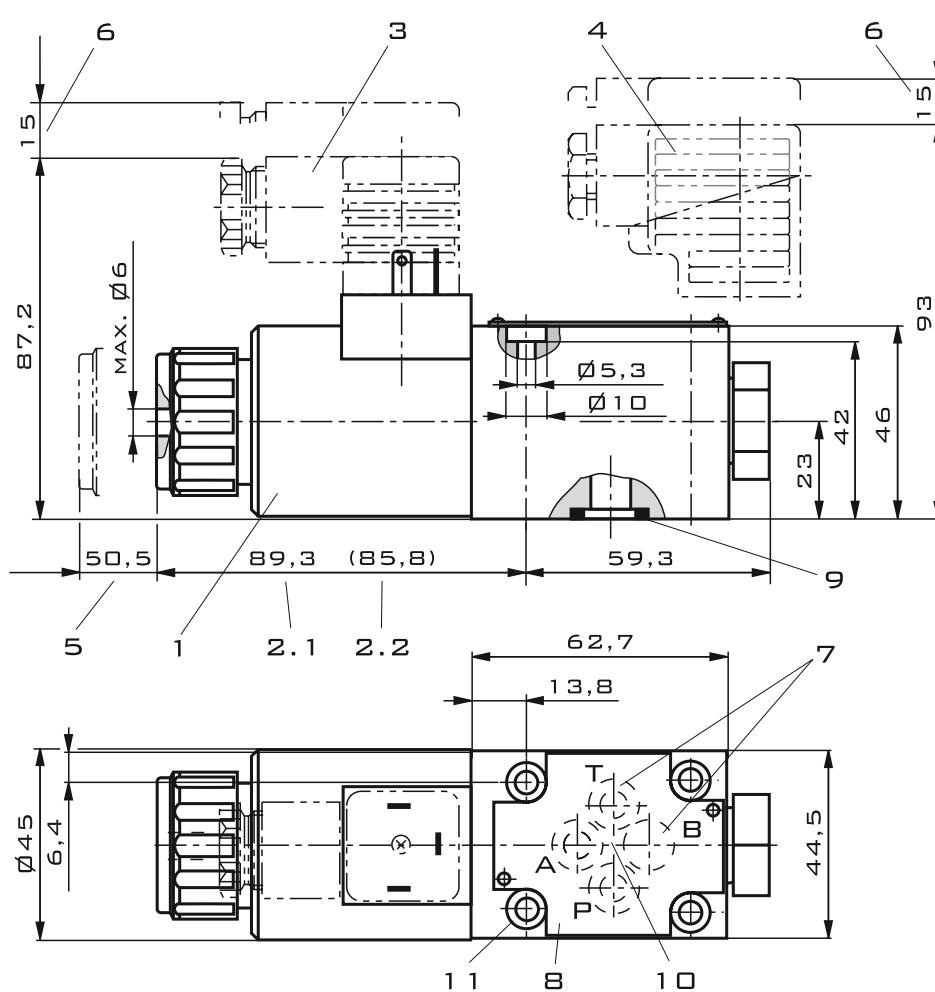

- 1 - SOLENOID "A"
- 2.1 - DIMENSION OF VALVE WITH CONCEALED MANUAL OVERRIDE "N9"
- 2.2 - DIMENSION OF VALVE WITHOUT MANUAL OVERRIDE
- 3 - MATING CONNECTOR WITHOUT CIRCUITRY (SEPARATE ORDER)
- 4 - MATING CONNECTOR WITH CIRCUITRY (SEPARATE ORDER)
- 5 - SPACE REQUIRED FOR REMOVING THE COIL
- 6 - SPACE REQUIRED FOR REMOVING THE MATING CONNECTOR
- 7 - ATTENTION!
PORT B IS PROVIDED AS BLIND COUNTERBORE ON 3/2 DIRECTIONAL SEAT VALVES.
WITH 2/2 DIRECTIONAL SEAT VALVES, PORT T IS BLOCKED INTERNALLY.
- 8 - NAMEPLATE
- 9 - IDENTICAL SEAL RINGS FOR PORTS A, B AND T; SEAL RING FOR PORT P. O-RING 9.25X1.78.
- 10 - PORTING PATTERN ACCORDING TO DIN 24340 FORM A (WITHOUT LOCATING HOLE),
OR ACCORDING TO ISO 4401-03-02-0-05 AND NFPA T3.5.1 R2-2002 D03
(WITH LOCATING HOLE FOR LOCATING PIN ISO 8752-3X8-ST).
- 11 - VALVE FIXING SCREW: M5X50

SUBPLATE INSTALLATION DIMENSIONS

4/2 DIRECTIONAL SEAT VALVE

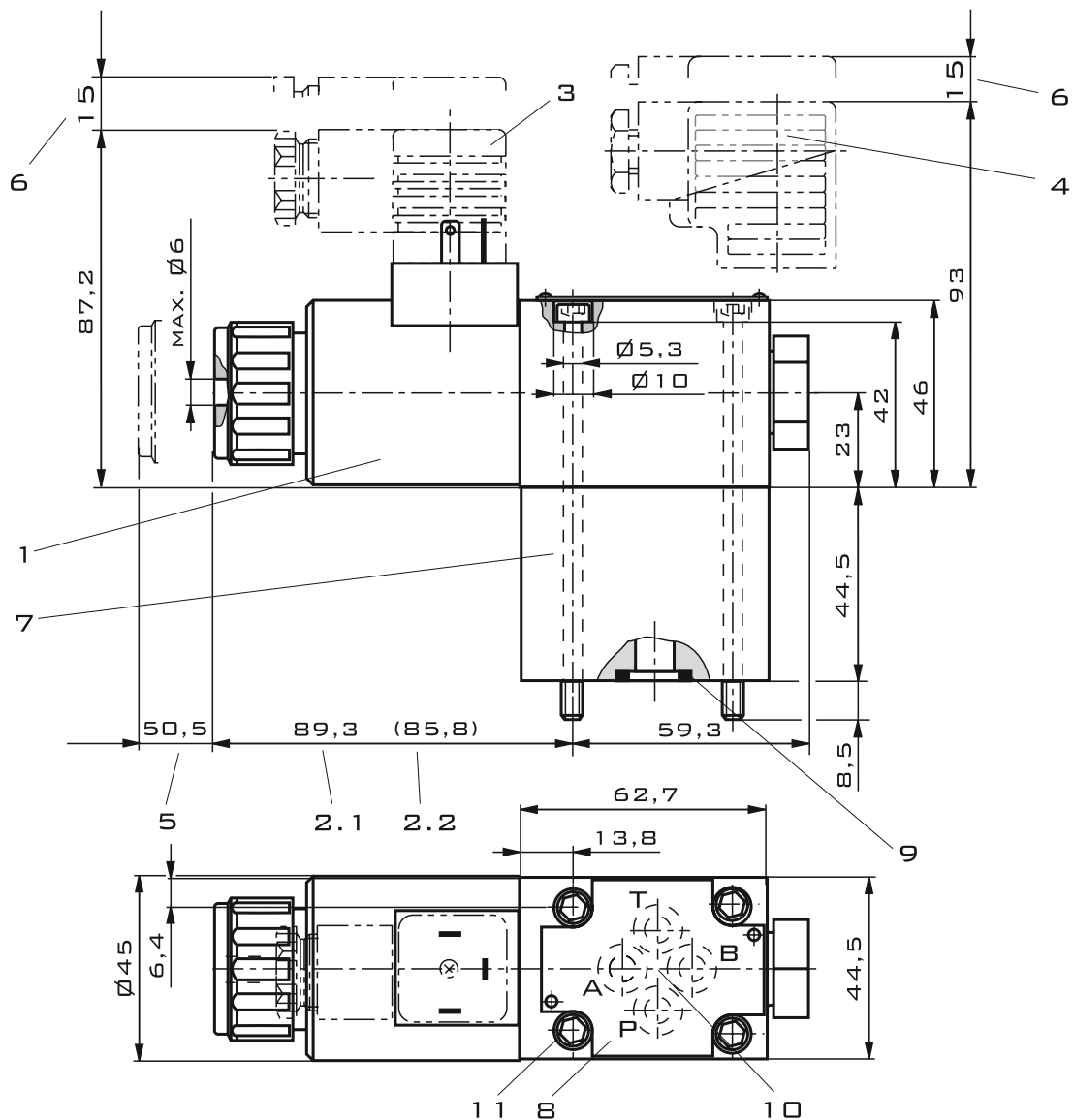

- 1 - SOLENOID "A"
- 2.1 - DIMENSION OF VALVE WITH CONCEALED MANUAL OVERRIDE "N9"
- 2.2 - DIMENSION OF VALVE WITHOUT MANUAL OVERRIDE
- 3 - MATING CONNECTOR WITHOUT CIRCUITRY (SEPARATE ORDER)
- 4 - MATING CONNECTOR WITH CIRCUITRY (SEPARATE ORDER)
- 5 - SPACE REQUIRED FOR REMOVING THE COIL
- 6 - SPACE REQUIRED FOR REMOVING THE MATING CONNECTOR
- 7 - PLUS-1 PLATE
- 8 - NAMEPLATE
- 9 - IDENTICAL SEAL RINGS FOR PORTS A, B AND T; SEAL RING FOR PORT P. O-RING 9.25X1.78.
- 10 - PORTING PATTERN ACCORDING TO DIN 24340 FORM A (WITHOUT LOCATING HOLE), OR ACCORDING TO ISO 4401-03-02-0-05 AND NFPA T3.5.1 R2-2002 D03 (WITH LOCATING HOLE FOR LOCATING PIN ISO 8752-3X8-ST).
- 11 - VALVE FIXING SCREW: M5X50



THROTTLE INSERT

THE USE OF A THROTTLE INSERT IS REQUIRED WHEN DUE TO PREVAILING OPERATING CONDITIONS, FLOWS CAN OCCUR DURING THE SWITCHING PROCESSES, WHICH EXCEED THE PERFORMANCE LIMIT OF THE VALVE.

EXAMPLES:

- ACCUMULATOR OPERATION,
- USE AS PILOT CONTROL VALVE WITH INTERNAL PILOT FLUID TAPPING.

3/2 DIRECTIONAL SEAT VALVE

THE THROTTLE INSERT IS INSERTED IN PORT P OF THE SEAT VALVE.

4/2 DIRECTIONAL SEAT VALVE

THE THROTTLE INSERT IS INSERTED IN PORT P OF THE PLUS-1 PLATE.

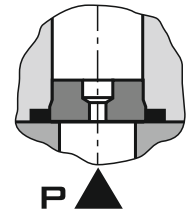

CHECK VALVE INSERT

THE CHECK VALVE INSERT ALLOWS A FREE FLOW FROM P TO A AND CLOSES A TO P LEAK-FREE.

3/2 DIRECTIONAL SEAT VALVE

THE CHECK VALVE INSERT IS INSERTED IN PORT P OF THE SEAT VALVE.

4/2 DIRECTIONAL SEAT VALVE

THE CHECK VALVE INSERT IS INSERTED IN PORT P OF THE PLUS-1 PLATE.

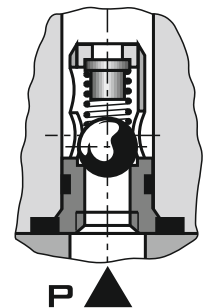

M-SED6

DIRECTIONAL SEAT VALVES

DISTRIBUTORI
OLEODINAMICI



ORDER CODE

M		SED	6		1XJ	/	350	C		N		/		
---	--	-----	---	--	-----	---	-----	---	--	---	--	---	--	--

3=3 MAIN PORTS
4=4 MAIN PORTS

6=6 SIZE

SPOOL TYPE:
UK, CK, D, Y

1XJ=10J-19J SERIES

350=OPERATING PRESSURE 350 BAR

C=WET-PIN SOLENOID WITH DETACHABLE COIL

G12=DC12V
G24=DC24V
W110R=AC110V
W220R=AC220V

N9=WITH CONCEALED MANUAL OVERRIDE

K4=WITHOUT PLUG
Z4=WITH SQUARE PLUG
Z5L=SQUARE PLUG WITH LIGHT

NO CODE=WITHOUT THROTTLE INSERT,
WITHOUT CHECK VALVE INSERT
B12=THROTTLE 1.2 MM
B15=THROTTLE 1.5 MM
B18=THROTTLE 1.8 MM
B20=THROTTLE 2.0 MM
B22=THROTTLE 2.2 MM

NO CODE=NBR SEALS
V=FKM SEALS