



**DISTRIBUTORI
OLEODINAMICI**

M-SEW6

DIRECTIONAL SEAT VALVES

M-SEW6 TYPE ARE DIRECTIONAL SEAT VALVES, DIRECT OPERATED, SOLENOID ACTUATION.

THESE VALVES ARE USED TO THE START, STOP AND DIRECTION OF FLOW.



TECHNICAL DATA

SIZE		6
MAX. FLOW RATE (L/MIN)		25
OPERATING PRESSURE (MPA)	A, B, P PORTS	42
	T PORT	10
FLUID TEMPERATURE (°C)		-30 - 80
FILTRATION ACCURACY (µM)		10
WEIGHT (KG)	2/2, 3/2 VALVE	1.5
	4/2 VALVE	2.3
VALVE BODY (MATERIAL)		CASTING PHOSPHATING SURFACE

CHARACTERISTIC CURVES

ΔP-Q CHARACTERISTIC CURVES
CHECK VALVE INSERT

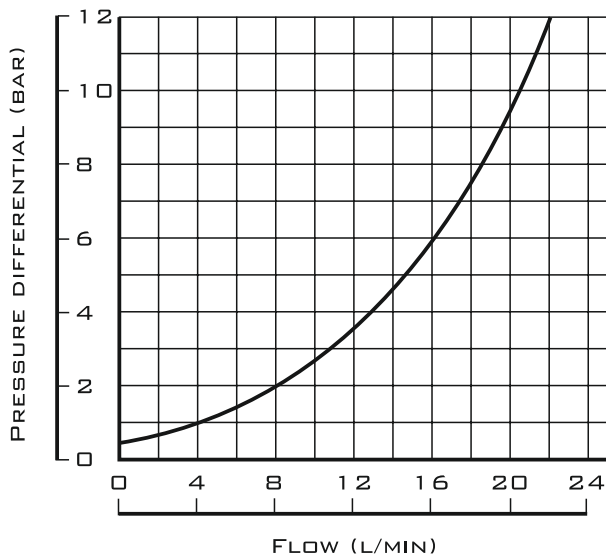

ΔP-Q CHARACTERISTIC CURVES
THROTTLE INSERT

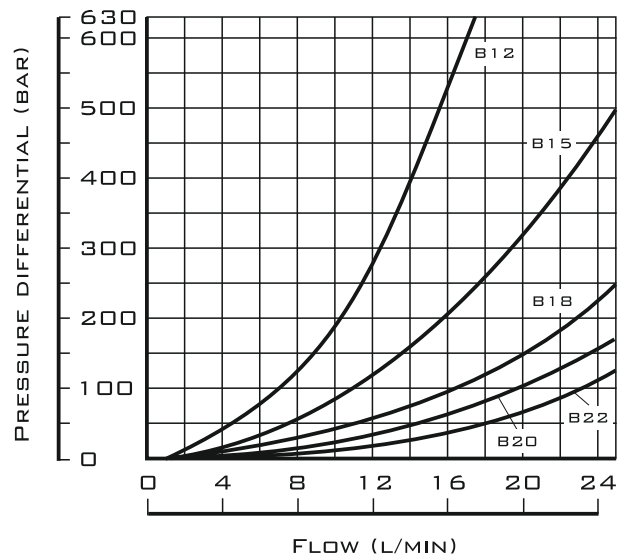

CHARACTERISTIC CURVES

ΔP -Q CHARACTERISTIC CURVES
2/2 DIRECTIONAL SEAT VALVE

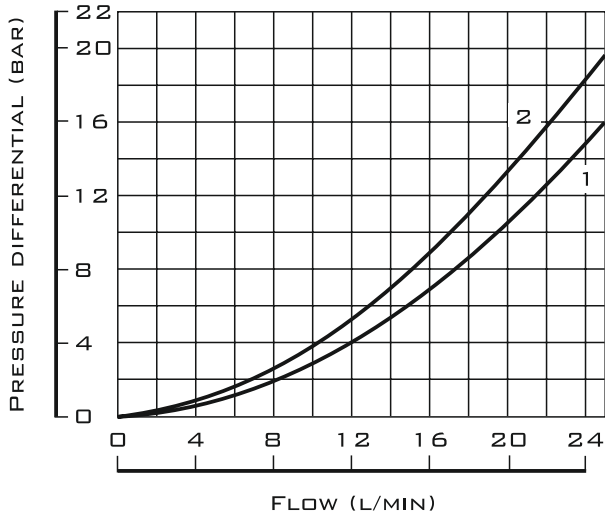

- 1 - M-2SEW6 - SPOOL SYMBOL "N", P → T;
2 - M-2SEW6 - SPOOL SYMBOL "P", P → T.

ΔP -Q CHARACTERISTIC CURVES
3/2 DIRECTIONAL SEAT VALVE

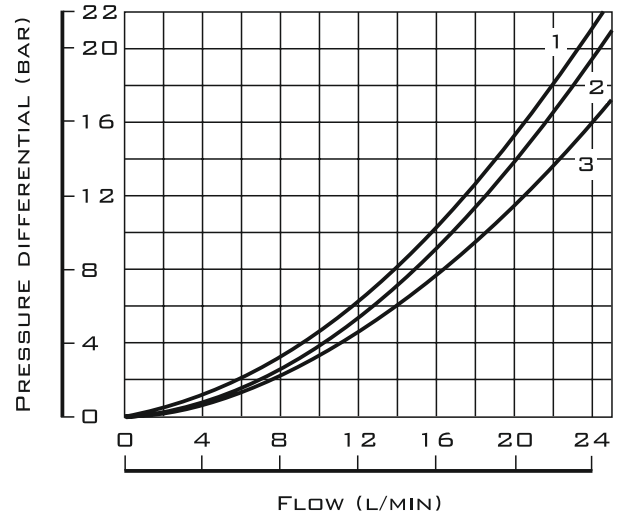

- 1 - M-3SEW6 - SPOOL SYMBOL "U" & "C", A → T;
2 - M-3SEW6 - SPOOL SYMBOL "U", P → A;
3 - M-3SEW6 - SPOOL SYMBOL "C", P → A.

ΔP -Q CHARACTERISTIC CURVES
4/2 DIRECTIONAL SEAT VALVE

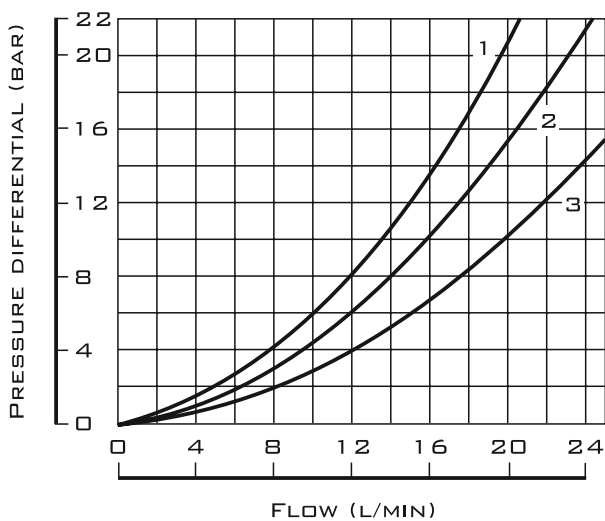

- 1 - M-4SEW6 - SPOOL SYMBOL "D" & "Y", A → T;
2 - M-4SEW6 - SPOOL SYMBOL "D" & "Y", P → A;
3 - M-4SEW6 - SPOOL SYMBOL "D" & "Y", P → B AND B → T.

SEE ALSO:
WE6, WE10

SPOOL SYMBOLS

2/2 DIRECTIONAL SEAT VALVE

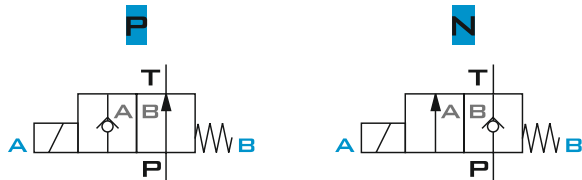

3/2 DIRECTIONAL SEAT VALVE

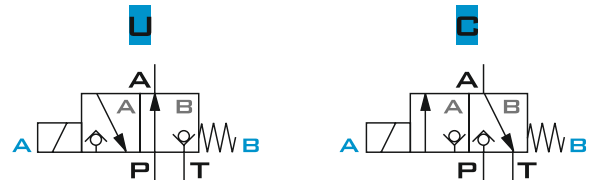

THE VALVE BASICALLY CONSISTS OF THE HOUSING (1), THE SOLENOID (2), THE HARDENED VALVE SYSTEM (3) AS WELL AS THE BALL/SPOOL (4) AS CLOSING ELEMENT.

IN THE INITIAL POSITION, THE BALL/SPOOL (4) IS PRESSED ONTO THE SEAT BY THE SPRING (9) AND IN THE SWITCHING POSITION BY THE SOLENOID (2). THE FORCE OF THE SOLENOID (2) ACTS VIA THE ANGLED LEVER (6) AND THE BALL (7) ON THE ACTUATING PLUNGER (8) THAT IS SEALED ON TWO SIDES. THE CHAMBER BETWEEN THE TWO SEALING ELEMENTS IS CONNECTED TO PORT P.

THEREFORE, THE VALVE SYSTEM (3) IS PRESSURE-COMPENSATED IN RELATION TO THE ACTUATING FORCES (SOLENOID OR RETURN SPRING).

THIS MEANS THE VALVES CAN BE USED UP TO 420 BAR.

3/2 DIRECTIONAL SEAT VALVES FEATURE "NEGATIVE SPOOL OVERLAP". THEREFORE, PORT T MUST ALWAYS BE CONNECTED.

THAT MEANS THAT DURING THE SWITCHING PROCESS - FROM THE STARTING OF THE OPENING OF ONE VALVE SEAT TO THE CLOSING OF THE OTHER VALVE SEAT - PORTS P-A-T ARE CONNECTED WITH EACH OTHER. HOWEVER, THIS PROCESS TAKES PLACE WITHIN SUCH A SHORT TIME THAT IT IS IRRELEVANT IN NEARLY ALL APPLICATIONS.

THE MANUAL OVERRIDE (10) ALLOWS FOR THE SWITCHING OF THE VALVE WITHOUT SOLENOID ENERGIZATION.

ATTENTION!

MAKE SURE THAT THE SPECIFIED MAXIMUM FLOW IS NOT EXCEEDED! USE A THROTTLE INSERT FOR LIMITING THE FLOW, IF NECESSARY.

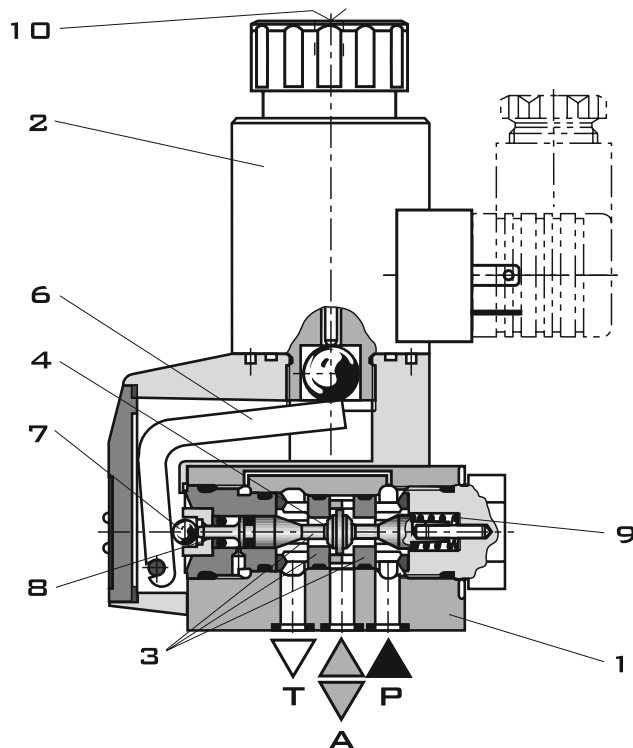

M-3SEW6 U...

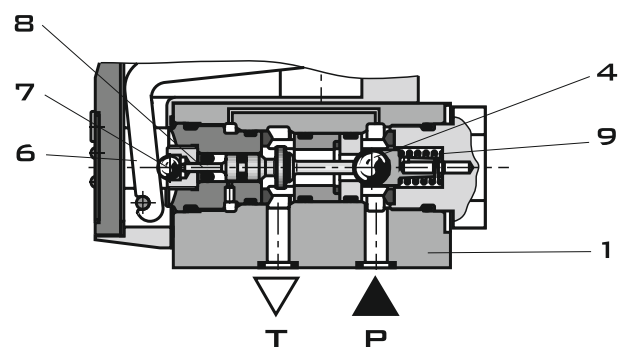

M-2SEW6 N...

SPOOL SYMBOLS

4/2 DIRECTIONAL SEAT VALVE

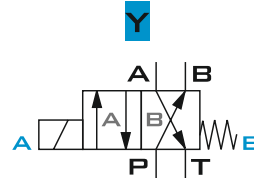
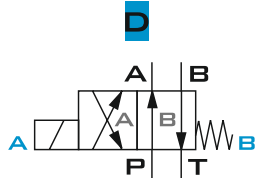

WITH A SANDWICH PLATE UNDER THE 3/2 DIRECTIONAL SEAT VALVE, THE FUNCTION OF A 4/2 DIRECTIONAL SEAT VALVE IS ACHIEVED.

FUNCTION OF THE SANDWICH PLATE

INITIAL POSITION: THE MAIN VALVE IS NOT ACTUATED. THE SPRING (9) HOLDS THE BALL (4.1) ON THE SEAT (11). PORT P IS BLOCKED AND A IS CONNECTED TO T. APART FROM THAT, ONE PILOT LINE IS CONNECTED FROM A TO THE LARGE AREA OF THE CONTROL SPOOL (12), WHICH IS THUS UNLOADED TO THE TANK.

THE PRESSURE APPLIED VIA P NOW PUSHES THE BALL (13) ONTO THE SEAT (14). NOW, P IS CONNECTED TO B, AND A TO T.

TRANSITION POSITION: WHEN THE MAIN VALVE IS ACTUATED, THE SPOOL (4.2) IS SHIFTED AGAINST THE SPRING (9) AND PRESSED ONTO THE SEAT (15). PORT T IS CLOSED; P, A, AND B ARE BRIEFLY CONNECTED TO EACH OTHER.

SPOOL POSITION: P IS CONNECTED TO A. AS THE PUMP PRESSURE ACTS VIA A ON THE LARGE AREA OF THE CONTROL SPOOL (12), THE BALL (13) IS PRESSED ONTO THE SEAT (16). THEREFORE, B IS CONNECTED TO T, AND P TO A.

ATTENTION!

IF THE ANNULUS AREA OF DIFFERENTIAL CYLINDERS IS NOT CONNECTED TO PORT A, A PRESSURE PEAK IS CREATED IN PORT B DURING THE SWITCHING PROCESS DUE TO THE PRESSURE INTENSIFICATION. THIS PRESSURE PEAK MAY EXCEED THE MAXIMUM OPERATING PRESSURE OVER THE PERMISSIBLE LIMIT.

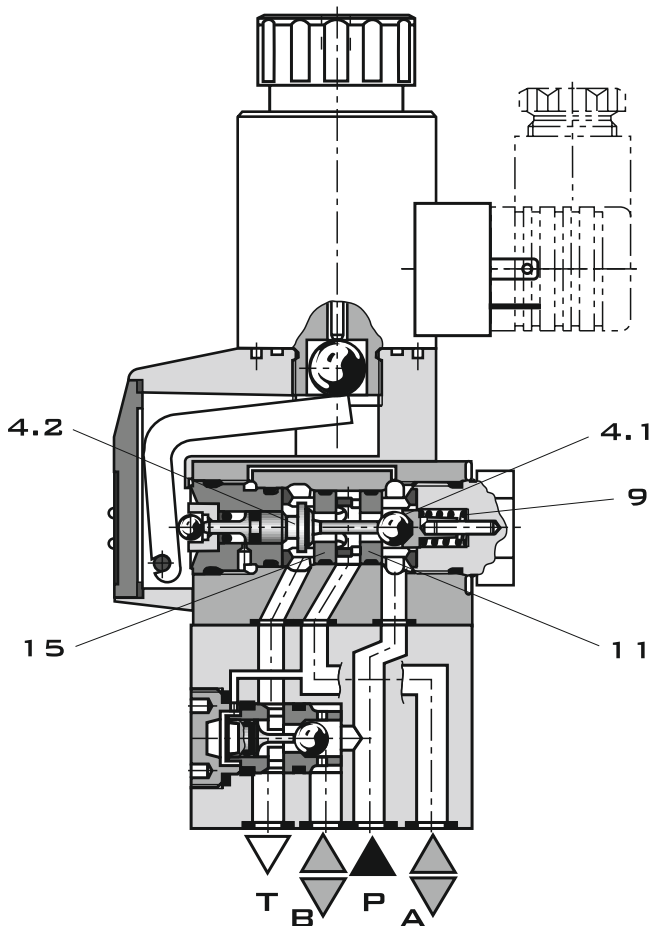

M-4SEW6 Y...

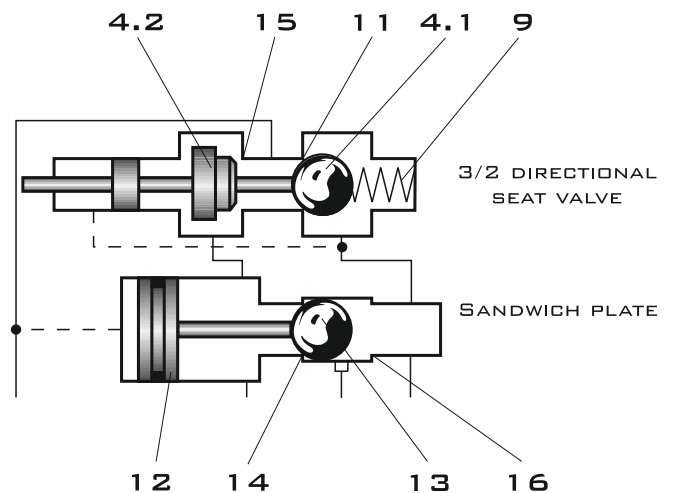

INITIAL POSITION

SUBPLATE INSTALLATION DIMENSIONS

2/2 AND 3/2 DIRECTIONAL SEAT VALVE

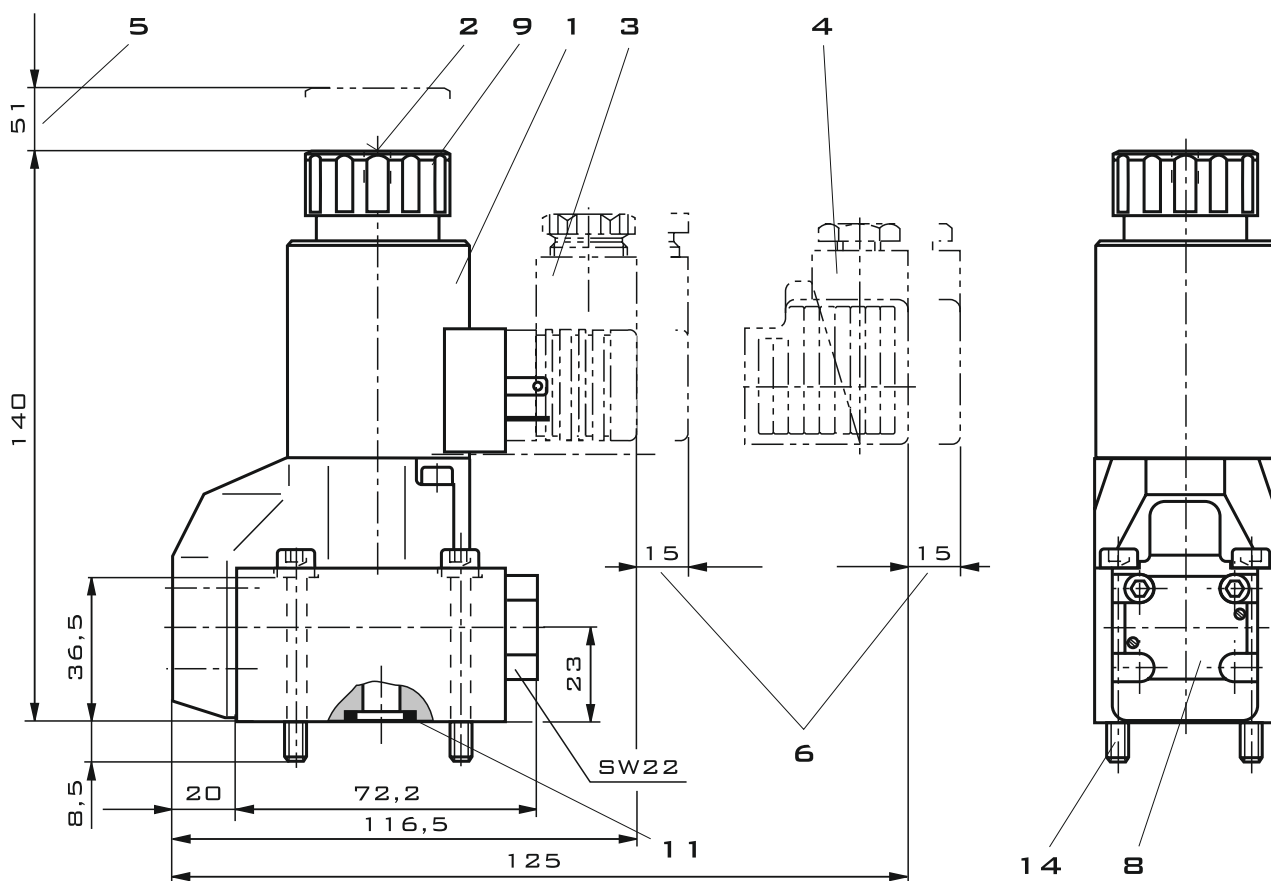

3/2 VALVE



2/2 VALVE

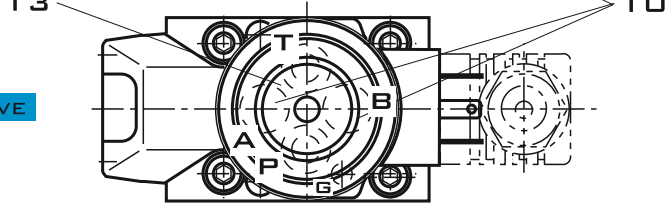

- 1 - SOLENOID "A"
- 2 - CONCEALED MANUAL OVERRIDE "N9"
- 3 - MATING CONNECTOR WITHOUT CIRCUITRY (SEPARATE ORDER)
- 4 - MATING CONNECTOR WITH CIRCUITRY (SEPARATE ORDER)
- 5 - SPACE REQUIRED TO REMOVE THE COIL
- 6 - SPACE REQUIRED FOR REMOVING THE MATING CONNECTOR
- 7 - SANDWICH PLATE
- 8 - NAMEPLATE
- 9 - MOUNTING NUT, TIGHTENING TORQUE $M_A = 4 \text{ N}\cdot\text{M}$
- 10 - WITH 3/2 DIRECTIONAL SEAT VALVES PORT B IS DESIGNED AS BLIND COUNTERBORE; WITH 2/2 DIRECTIONAL SEAT VALVES PORTS A AND B ARE AVAILABLE AS BLIND COUNTERBORES
- 11 - IDENTICAL SEAL RINGS FOR PORTS A, B, AND T; SEAL RING FOR PORT P
- 12 - PORTING PATTERN ACCORDING TO DIN 24340 FORM A
- 13 - PORTING PATTERN ACCORDING TO ISO 4401-03-02-0-05 AND NFPA T3.5.1 R2-2002 D03
- 14 - FOR VALVE MOUNTING SCREWS

SUBPLATE INSTALLATION DIMENSIONS

4/2 DIRECTIONAL SEAT VALVE

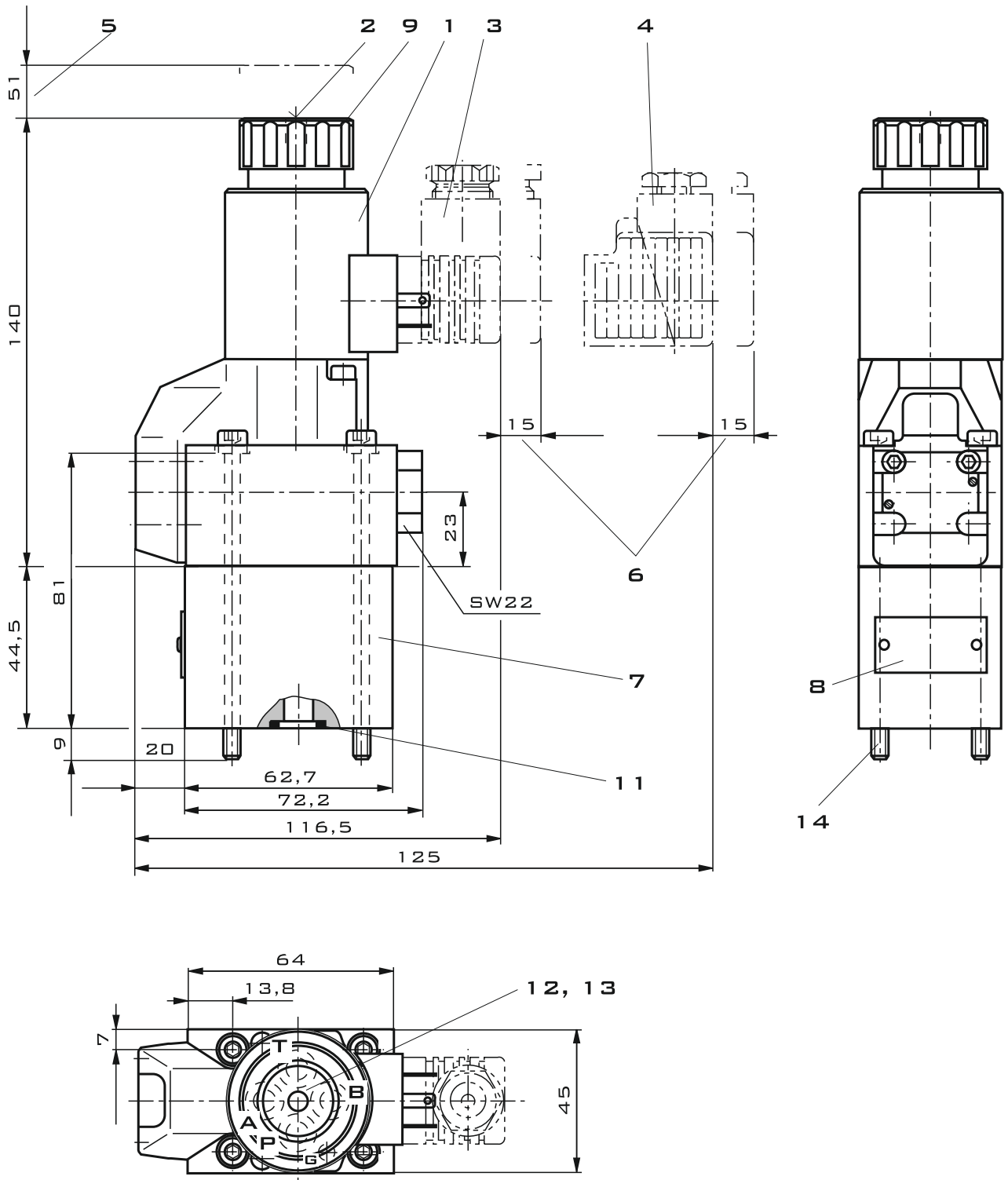



THROTTLE INSERT

THE USE OF A THROTTLE INSERT IS REQUIRED WHEN DUE TO PREVAILING OPERATING CONDITIONS, FLOWS CAN OCCUR DURING THE SWITCHING PROCESSES, WHICH EXCEED THE PERFORMANCE LIMIT OF THE VALVE.

EXAMPLES:

- ACCUMULATOR OPERATION
- USE AS PILOT CONTROL VALVE WITH INTERNAL PILOT FLUID TAPPING

2/2 AND 3/2 DIRECTIONAL SEAT VALVE

THE THROTTLE INSERT IS INSERTED IN PORT P OF THE SEAT VALVE.

4/2 DIRECTIONAL SEAT VALVE

THE THROTTLE INSERT IS INSERTED IN PORT P OF THE SANDWICH PLATE.

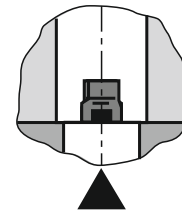

M-SEW6

DIRECTIONAL SEAT VALVES

DISTRIBUTORI
OLEODINAMICI



ORDER CODE

M		SEW	6		30	/	420	M			K4		
---	--	-----	---	--	----	---	-----	---	--	--	----	--	--

2=2 MAIN PORTS
3=3 MAIN PORTS
4=4 MAIN PORTS

6=6 SIZE

SPOOL TYPE:
P, N, U, C, D, Y

30=30 SERIES

420=OPERATING PRESSURE 420 BAR

M=HIGH-POWER SOLENOID WITH DETACHABLE COIL

G24=DC24V
G205=DC205V

N9=WITH CONCEALED HAND EMERGENCY
NO CODE=WITHOUT HAND EMERGENCY

K4=PROTECT COVER WITHOUT PLUG

NO CODE=WITHOUT THROTTLE INSERT
B12=THROTTLE 1.2 MM
B15=THROTTLE 1.5 MM
B20=THROTTLE 2.0 MM
B22=THROTTLE 2.2 MM
B18=THROTTLE 1.8 MM

NO CODE=NBR SEALS
V=FKM SEALS