



**DISTRIBUTORI
OLEODINAMICI**

WMM6

**MANUALLY OPERATED
DIRECTIONAL CONTROL VALVES**

WMM6 SERIES MANUALLY OPERATED DIRECTIONAL CONTROL VALVES ARE DIRECT TYPE DIRECTIONAL SPOOL VALVES. THESE VALVES ARE USED TO THE START, STOP AND DIRECTION OF FLOW. THIS SERIES WITH DETENT OR RETURN SPRING ARE AVAILABLE.



TECHNICAL DATA

SIZE		6
MAX. FLOW RATE (L/MIN)		60
OPERATING PRESSURE (MPA)	A, B, P PORTS	31.5
	T PORT	16
WEIGHT (KG)		1.5
VALVE BODY (MATERIAL)		CASTING PHOSPHATING SURFACE



CHARACTERISTIC CURVES

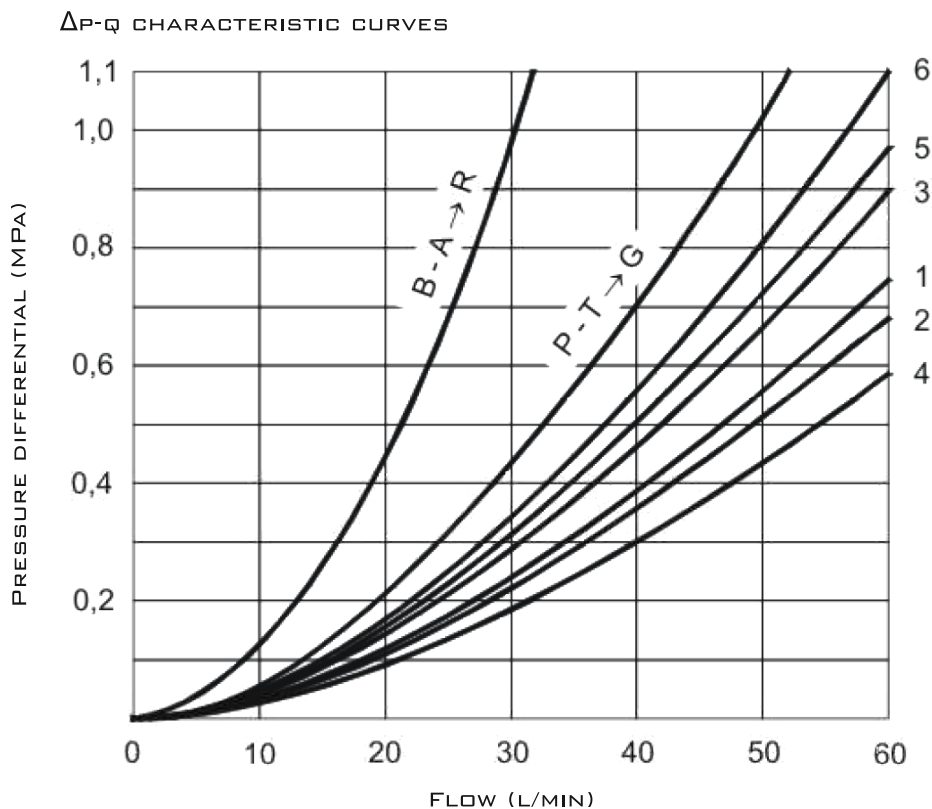

SPOOL SYMBOL	FLOW DIRECTION			
	P - A	P - B	A - T	B - T
A, B	3	3	-	-
C	1	1	3	1
D, Y	5	5	3	3
E	3	3	1	1
F	2	3	3	5
G	5	3	6	6
H	2	4	2	2
J, Q	1	1	2	1
L	1	1	2	2
M	2	4	3	3
P	2	3	3	5
R	5	5	4	-
T	5	3	6	6
U	3	1	3	3
V	1	2	1	1
W	1	1	2	2



SPOOL SYMBOLS

2-POSITION VALVES

3-POSITION VALVES

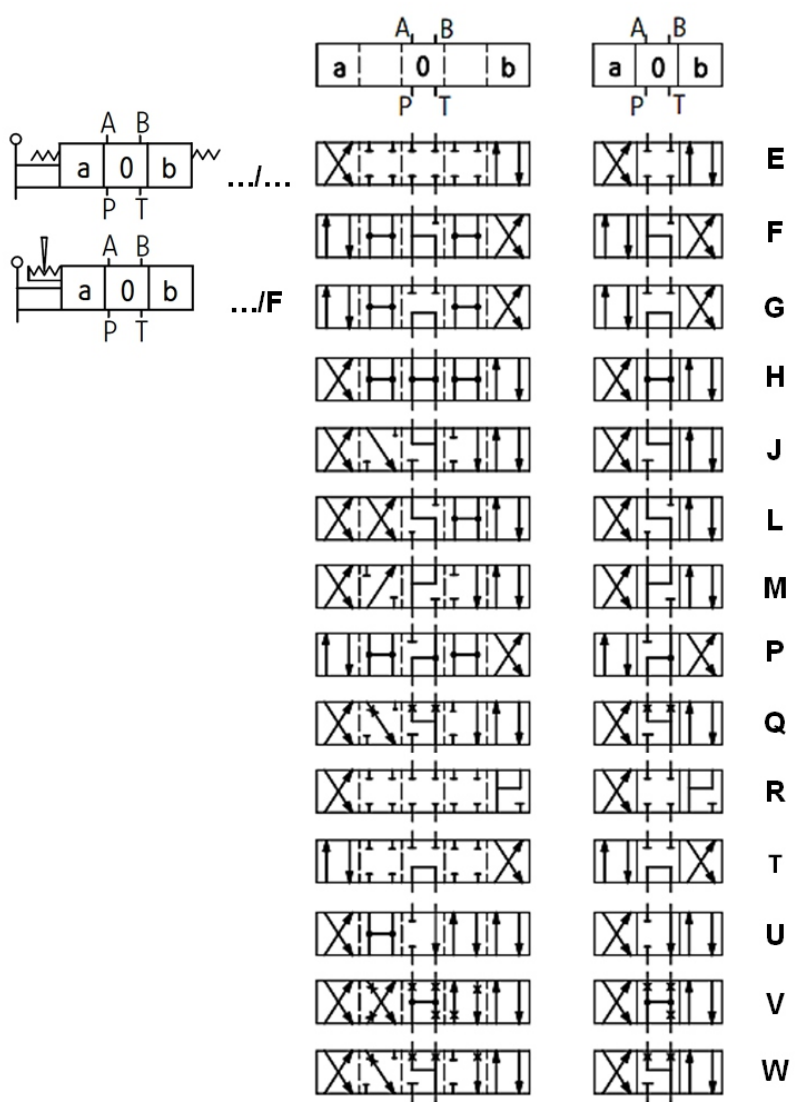
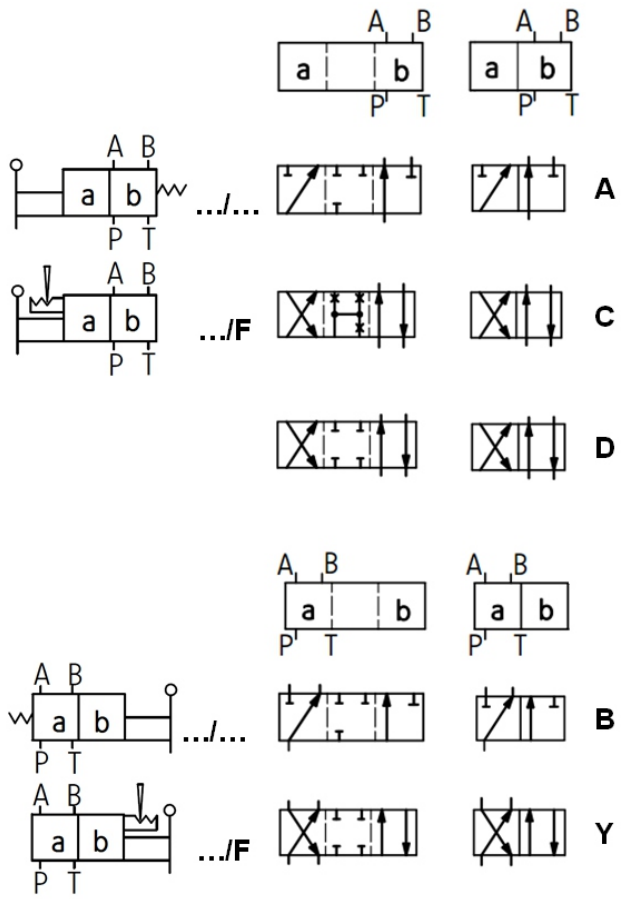

SEE ALSO:
WMM10, WMM16,
WMM25

SUBPLATE INSTALLATION DIMENSIONS

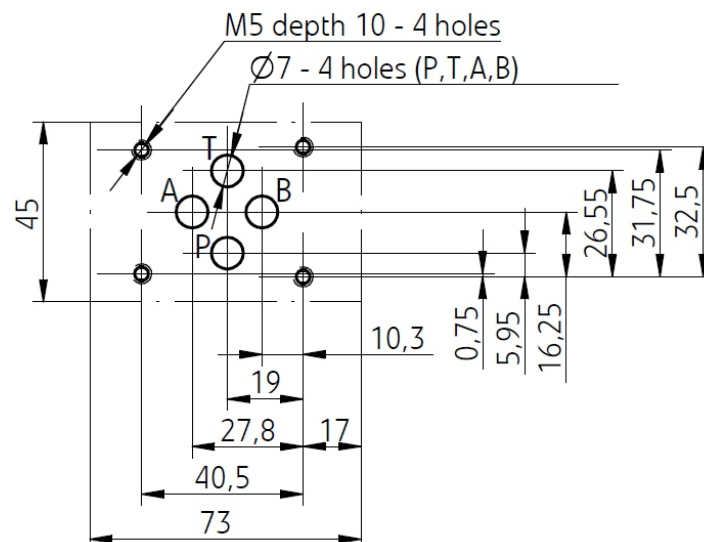
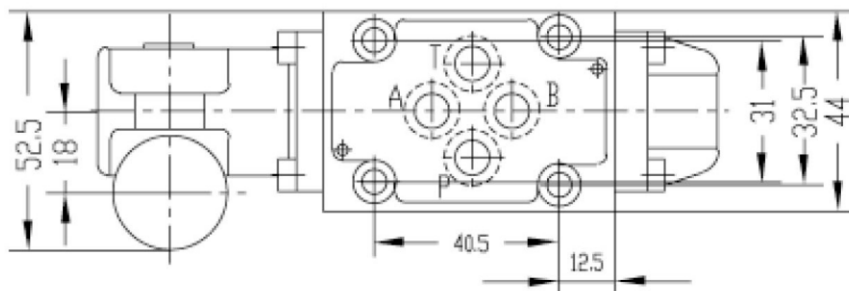
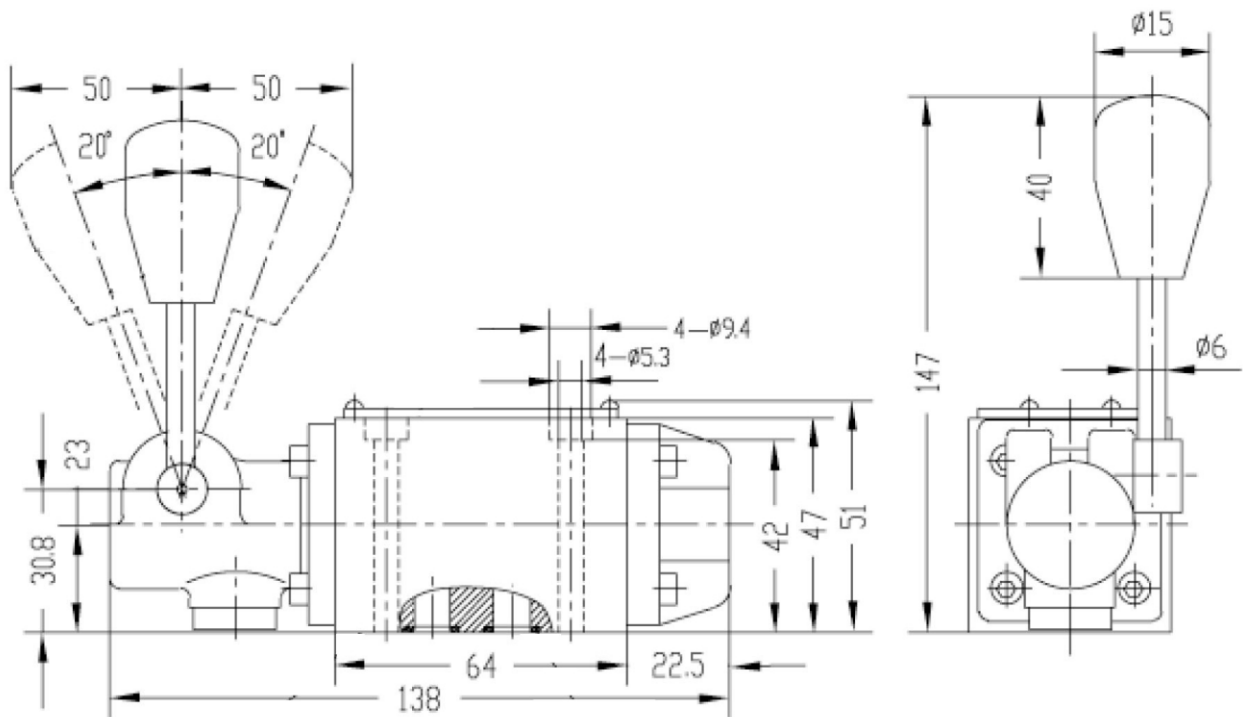



DISTRIBUTORI
OLEODINAMICI

WMM6

MANUALLY OPERATED
DIRECTIONAL CONTROL VALVES

ORDER CODE

	WMM	6							
--	-----	---	--	--	--	--	--	--	--

3=3-WAY
4=4-WAY

6=6 SIZE

SPOOL TYPE

10=10 SERIES

50=50 SERIES

NO CODE=SPRING RETURN WITHOUT DETENT
F=DETENT WITHOUT SPRING RETURN

NO CODE=HANDLE ON SIDE OF
PORT A
L=HANDLE ON SIDE OF PORT B

NO CODE=MINERAL SUBSTANCE
HYDRAULIC OIL
V=PHOSPHATE EATER
HYDRAULIC OIL

NO CODE=WITHOUT THROTTLE INSERT
B0.8=THROTTLE 0.8 MM
B1.0=THROTTLE 1.0 MM
B1.2=THROTTLE 1.2 MM