



VALVOLE DI RITEGNO

Z2S6

PILOT OPERATED CHECK VALVES

Z2S6 SERIES ARE PILOT OPERATED CHECK VALVES.
 THIS VALVES ARE USED TO SHUT-OFF AN OIL FLOW IN ONE DIRECTION AND ALLOW FREE FLOW IN THE OPPOSITE DIRECTION.
 THEY CAN ALSO BE OPENED IN THE DIRECTION OF CLOSURE.

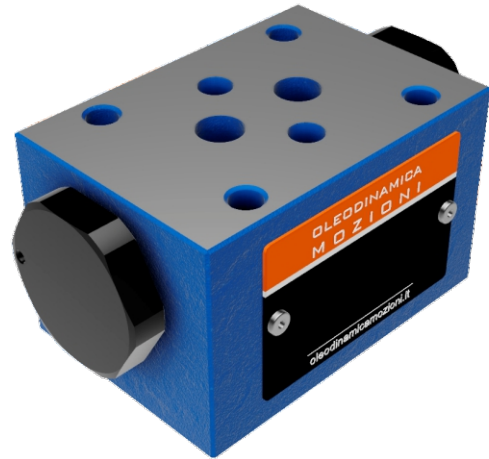

TECHNICAL DATA

SIZE	6
OPERATING PRESSURE (MPA)	31.5
MAX. FLOW RATE (L/MIN)	60
FLUID TEMPERATURE (°C)	-30 - 80
WEIGHT (KG)	1
VALVE BODY (MATERIAL)	CASTING PHOSPHATING SURFACE

SCHEMES

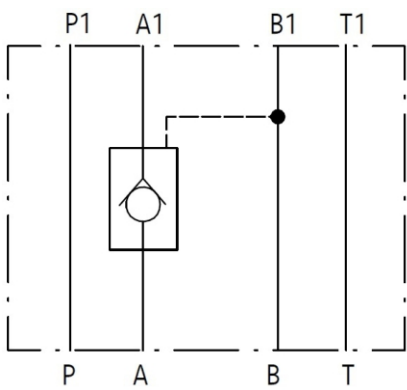

Z2S6 A

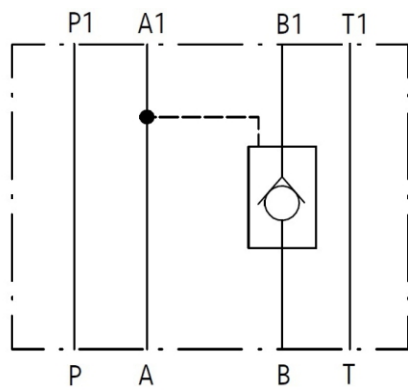

Z2S6 B

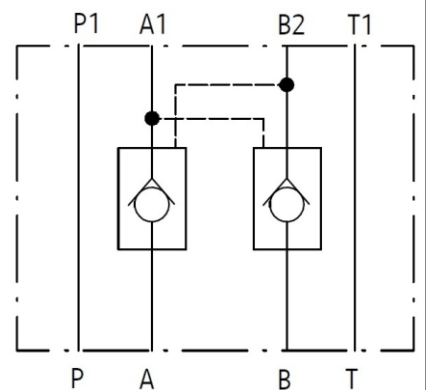

Z2S6

CHARACTERISTIC CURVES

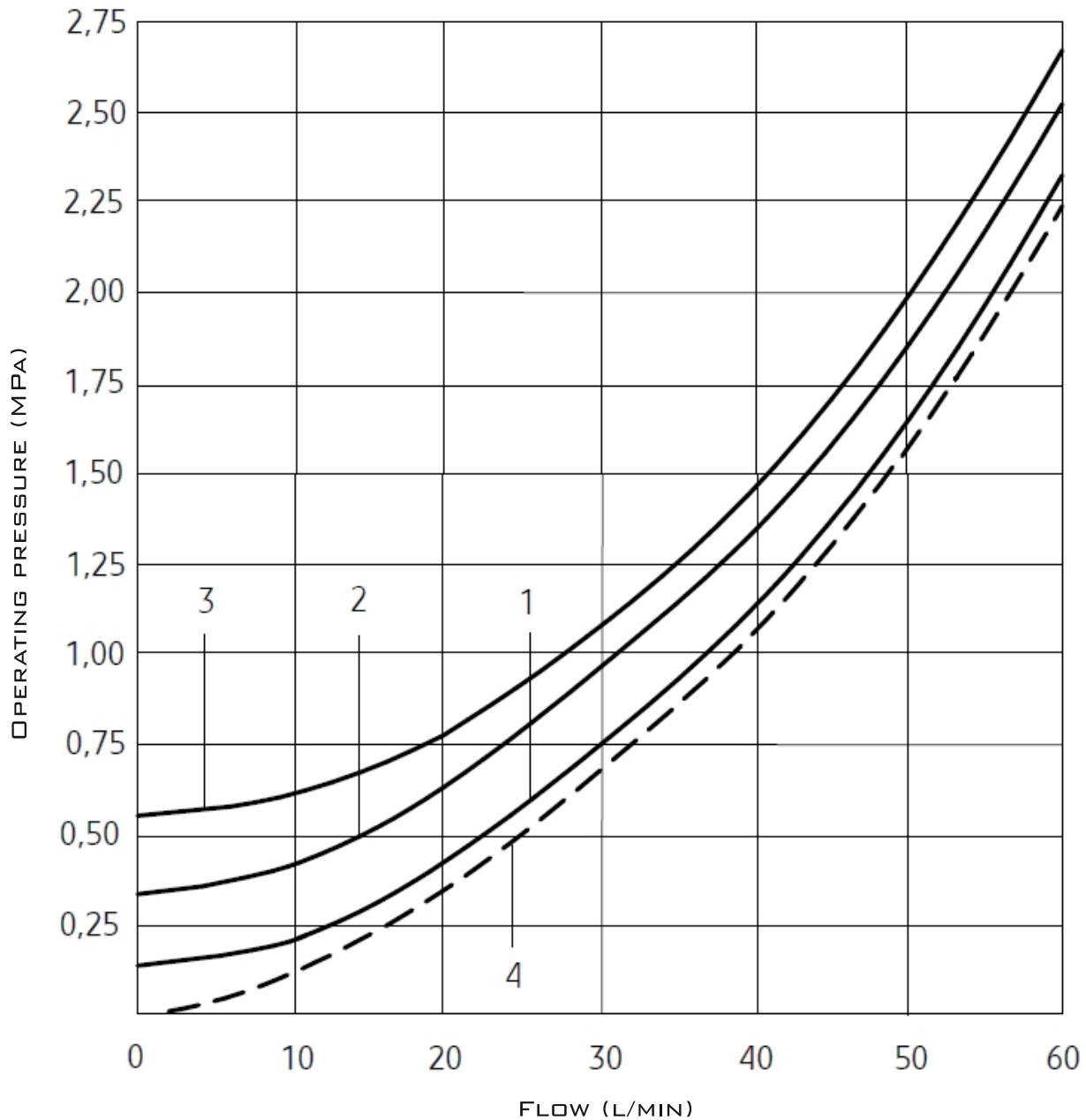

- 1 CURVE - OPENING PRESSURE 0.15 MPA, FLOW DIRECTION A1 → A, B1 → B;
 2 CURVE - OPENING PRESSURE 0.3 MPA, FLOW DIRECTION A1 → A, B1 → B;
 3 CURVE - OPENING PRESSURE 0.6 MPA, FLOW DIRECTION A1 → A, B1 → B;
 4 CURVE - FLOW DIRECTION A → A1, B → B1.



VALVOLE DI RITEGNO

Z2S6

PILOT OPERATED CHECK VALVES

SUBPLATE INSTALLATION DIMENSIONS

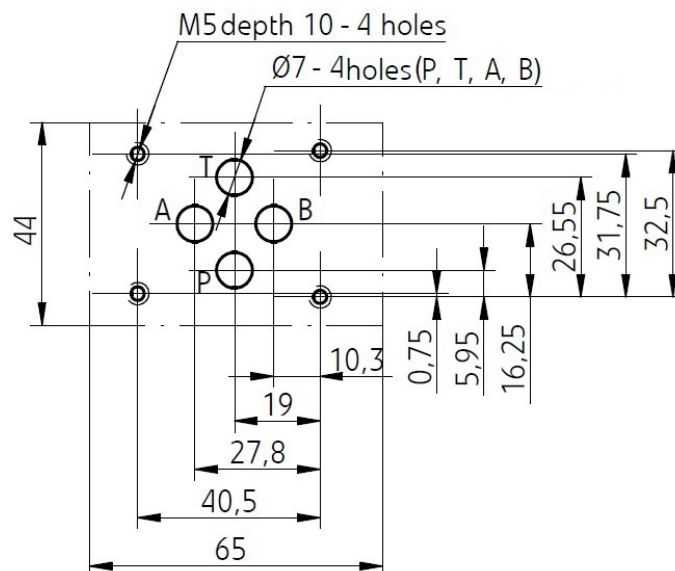
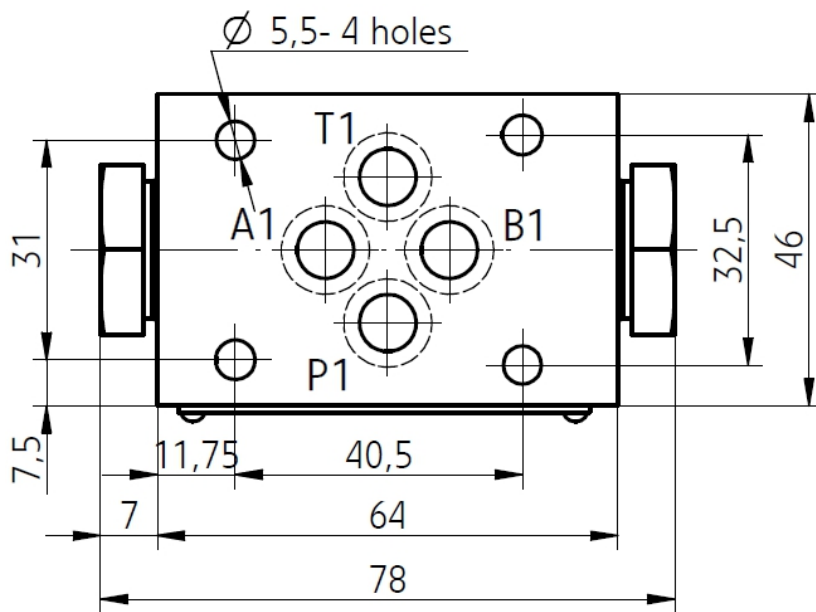
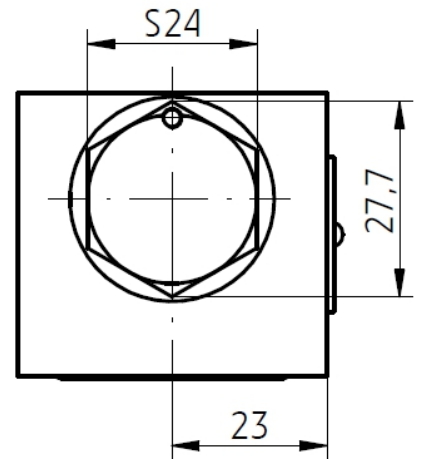
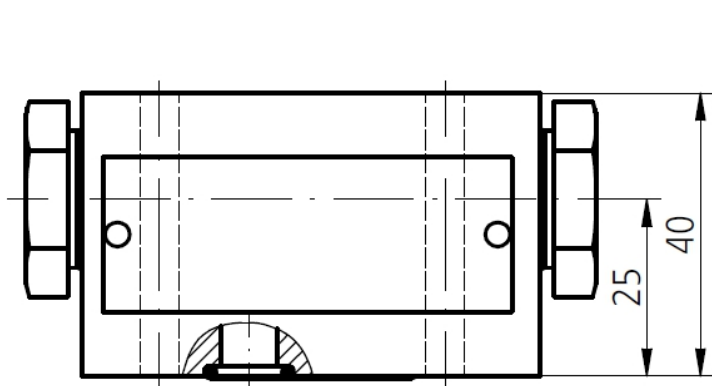

Z2S6

VALVOLE DI RITEGNO



PILOT OPERATED CHECK VALVES

ORDER CODE

Z2S	6				
-----	---	--	--	--	--

6=6 SIZE

NO CODE=PORT A, B WITH CHECK VALVE
A=PORT A WITH CHECK VALVE
B=PORT B WITH CHECK VALVE

1=OPENING PRESSURE 0.15 MPA
2=OPENING PRESSURE 0.3 MPA
3=OPENING PRESSURE 0.6 MPA

NO CODE=MINERAL
SUBSTANCE HYDRAULIC OIL
V=PHOSPHATE EATER
HYDRAULIC OIL

40=40 SERIES
60=60 SERIES