

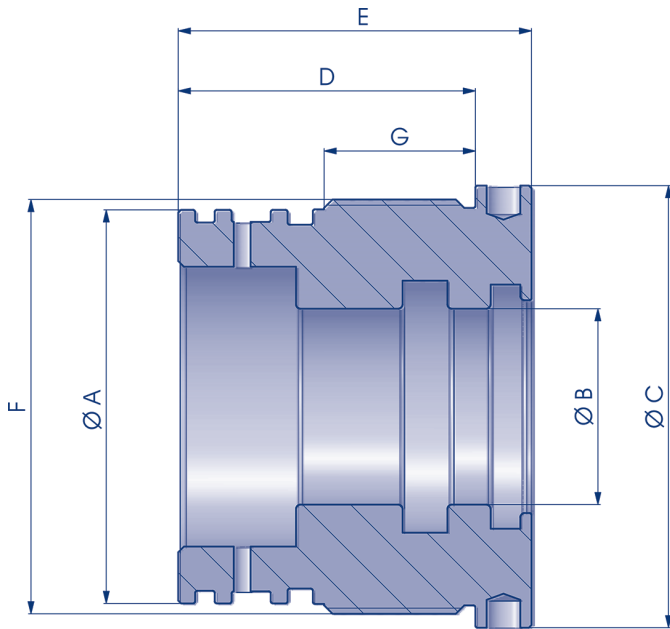

**TESTATA FRENANTE  
CUSHIONING HEAD BREMSKOPF  
TÊTE FREINANTE CABEZA FRENANTE**



NEW	COD.	A	B	C	D	E	F	G	Kg
•	NBTF04005020	40	20	49	45	53	M44X1.5	19	0,31
•	NBTF04005025	40	25	49	45	53	M44X1.5	19	0,26
	NBTF05006025	50	25	59	48	56	M54X1.5	22	0,52
	NBTF05006030	50	30	59	48	56	M54X1.5	22	0,46
	NBTF06007030	60	30	69	53	63	M64X1.5	27	0,84
	NBTF06007035	60	35	69	53	63	M64X1.5	27	0,75
	NBTF06007040	60	40	69	53	63	M64X1.5	27	0,67
	NBTF06307330	63	30	73	53	63	M68X1.5	25	0,97
	NBTF06307335	63	35	73	53	63	M68X1.5	25	0,88
	NBTF06307340	63	40	73	53	63	M68X1.5	25	0,80
	NBTF07008030	70	30	79	53	63	M74X1.5	27	1,22
	NBTF07008035	70	35	79	53	63	M74X1.5	27	1,12
	NBTF07008040	70	40	79	53	63	M74X1.5	27	1,01
	NBTF07008045	70	45	79	53	63	M74X1.5	27	0,92
	NBTF08009235	80	35	92	63	73	M85X2	33	1,95
	NBTF08009240	80	40	92	63	73	M85X2	33	1,78
	NBTF08009245	80	45	92	63	73	M85X2	33	1,67
	NBTF08009250	80	50	92	63	73	M85X2	33	1,53
•	NBTF09010540	90	40	104	63	73	M95X2	33	2,34
•	NBTF09010545	90	45	104	63	73	M95X2	33	2,18
•	NBTF09010550	90	50	104	63	73	M95X2	33	2,08
•	NBTF09010560	90	60	104	63	73	M95X2	33	1,69
	NBTF10011540	100	40	114	83	95	M105X2	51	4,08
	NBTF10011545	100	45	114	83	95	M105X2	51	3,92
	NBTF10011550	100	50	114	83	95	M105X2	51	3,75
	NBTF10011560	100	60	114	83	95	M105X2	51	3,24